

Title:	Niemals nur oberflächlich! <i>Zu Material, Technik und Ästhetik von Architekturoberfläche. Eine Einführung</i> <i>Case study: The Monastic complex of San Pietro al Monte in Civate (Italy)</i>
Chair:	Chair of Conservation-Restoration, Art Technology and Conservation Science Prof. Thomas Danzl, Dr. Fonti Roberta
Language:	English support (i.e. learning materials in German/English, individual reviews in English)
Study level:	Bachelor
Kick off:	13/04/2021
Meetings:	Every Tuesday
Interm. Reviews:	01/06; 06/07
Final Presentation:	10/08
ECTS:	Credits (9 ECTS)
Remarks:	In collaboration with Dr. Jacopo Benedetti, TUM Visiting Lecturer Excursion to Milan (Civate – Lake of Lecco), if possible <i>not compulsory for the successful completion of the course</i>

A striking example of the Lombard Romanesque
'preserving an extraordinary amount of Carolingian character'

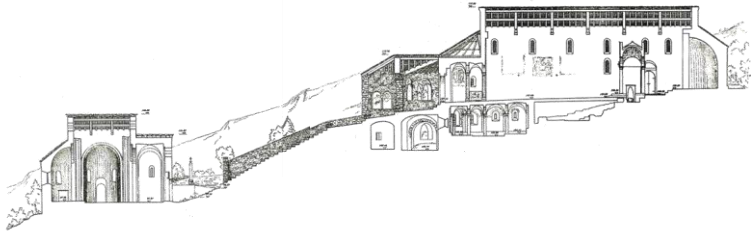

The Monastic complex of San Pietro al Monte Civate, Italy (VIII – XI Century)



CASE STUDY

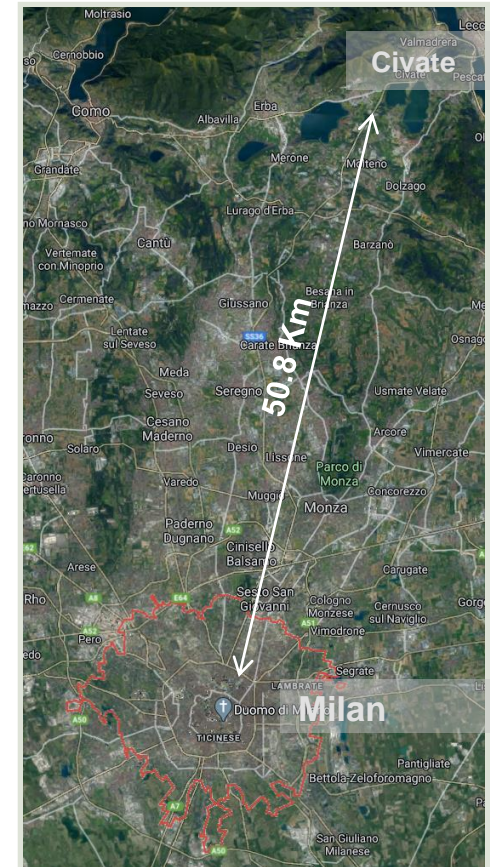

The Church

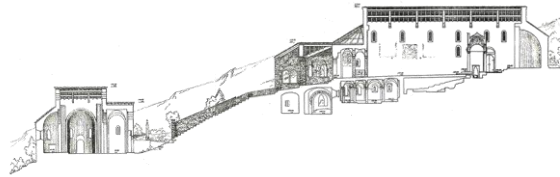

The Monastic complex of San Pietro al Monte
Civate, Italy (VIII – XI Century)



Conservation-Restoration PROJECT

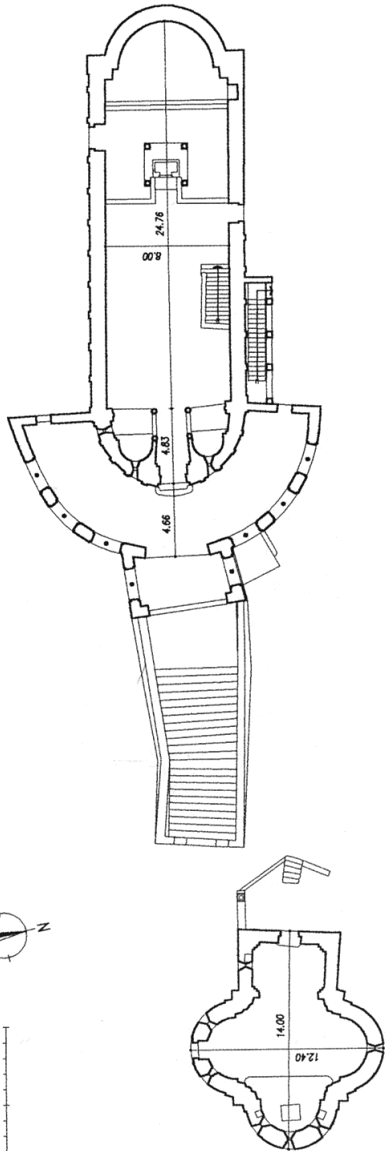

THE MONASTIC COMPLEX

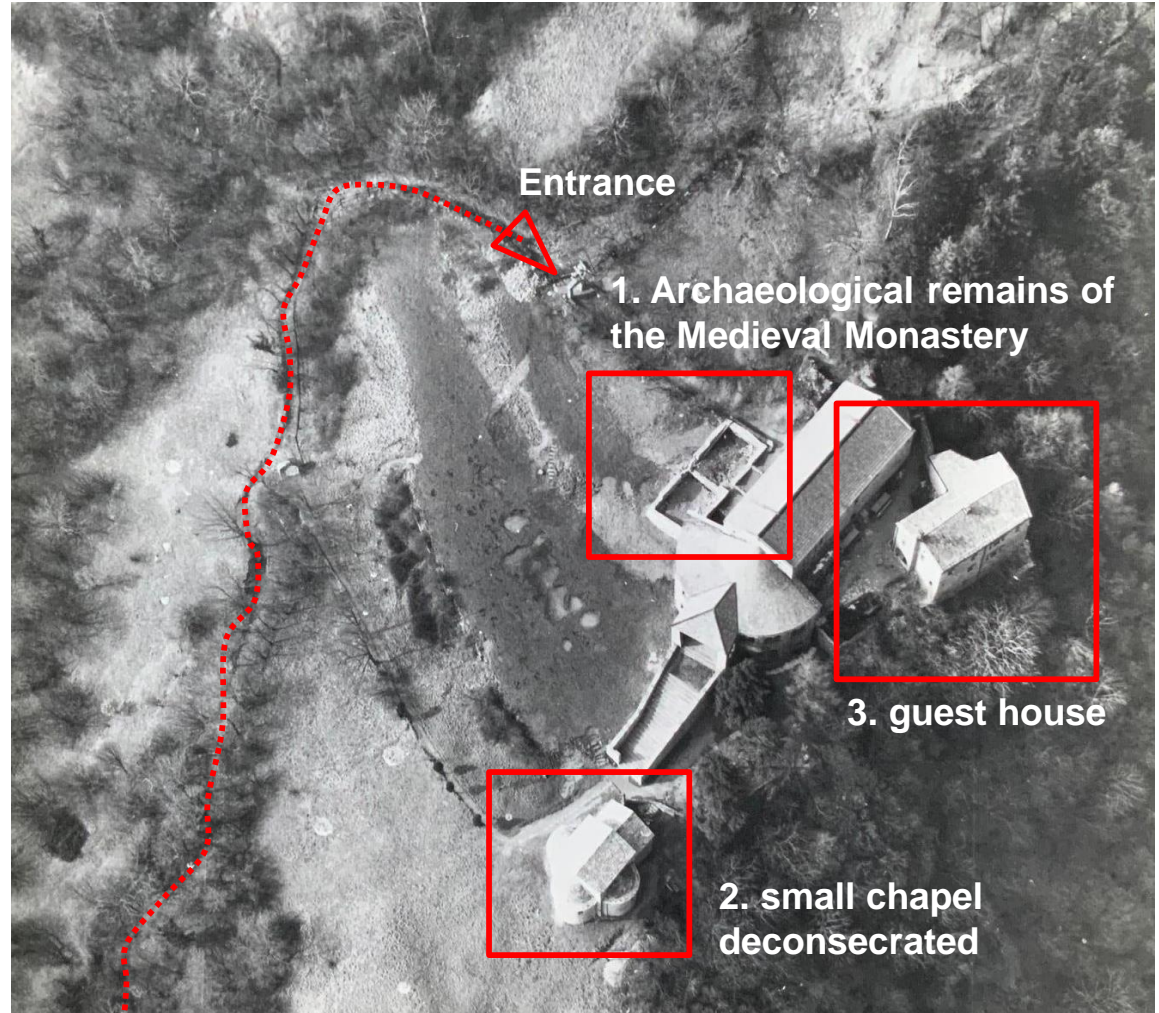

Task 1

The Bell Tower and The Southern elevation



The Monastic complex of San Pietro al Monte Civate, Italy (VIII – XI Century)



Conservation-Restoration PROJECT

„Which is the historic image we wish to transfer to posterity?“

Design Problem

The Bell Tower

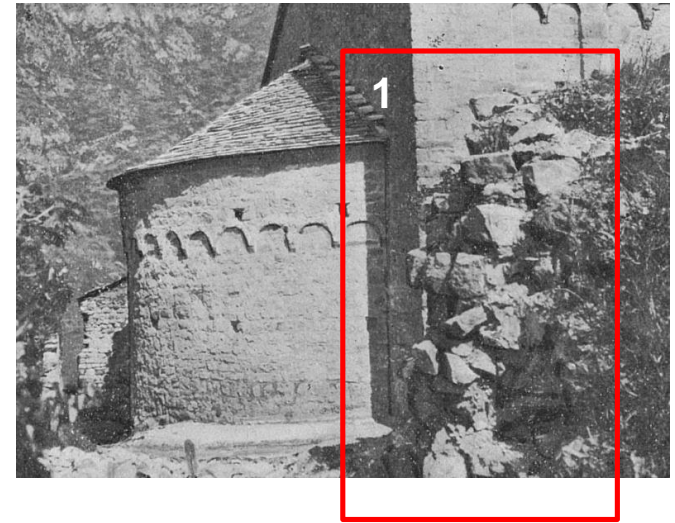
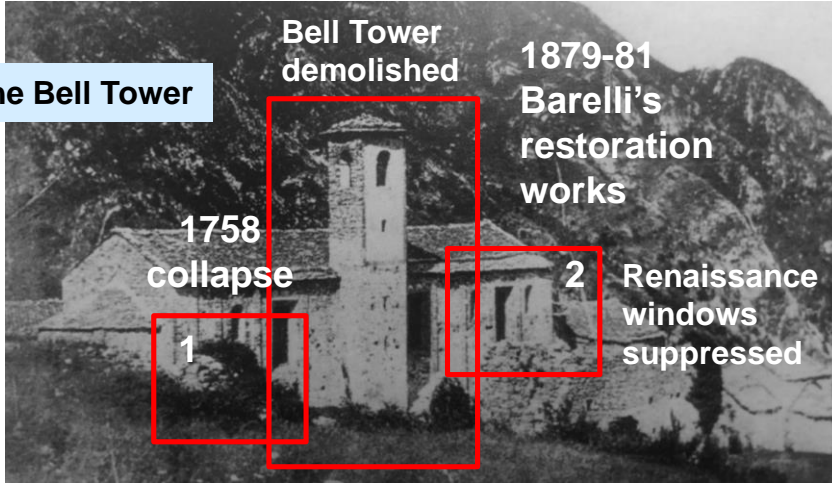

The Southern Elevation

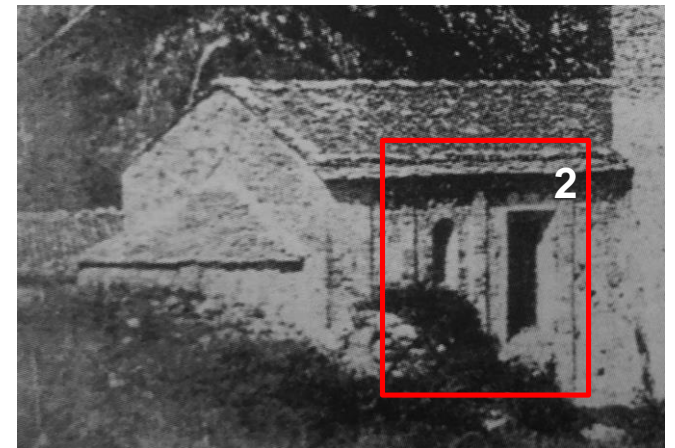
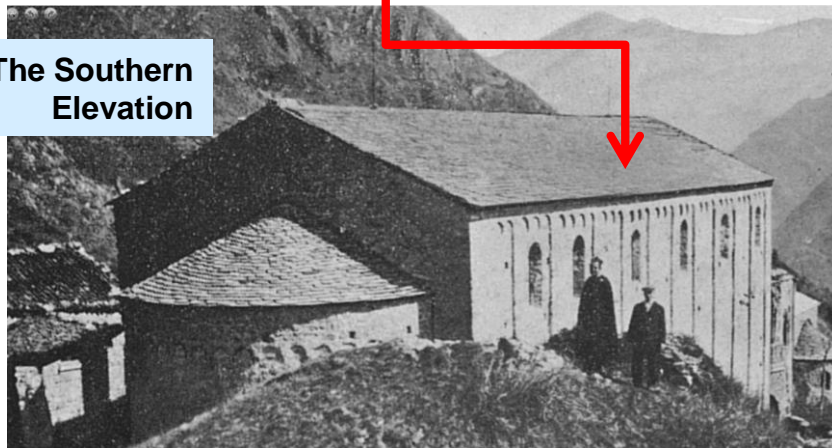

Task 2 The Narthex (esonartece) and its Holy staircases



The Monastic complex of San Pietro al Monte Civate, Italy (VIII – XI Century)



Conservation-Restoration PROJECT

Design Problem

„Which is the historic image of the Narthex we wish to transfer to posterity?“

The Narthex lateral view

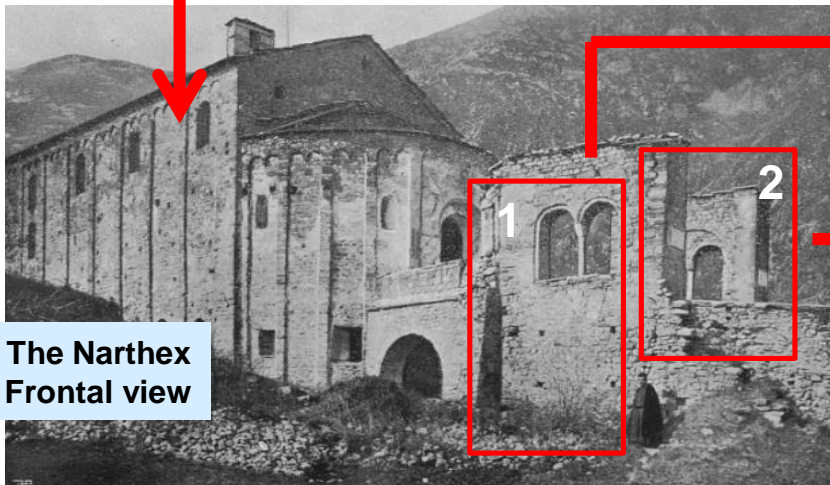
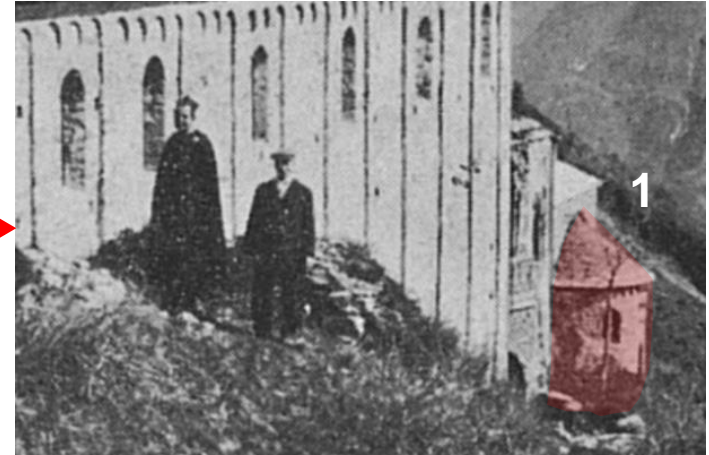
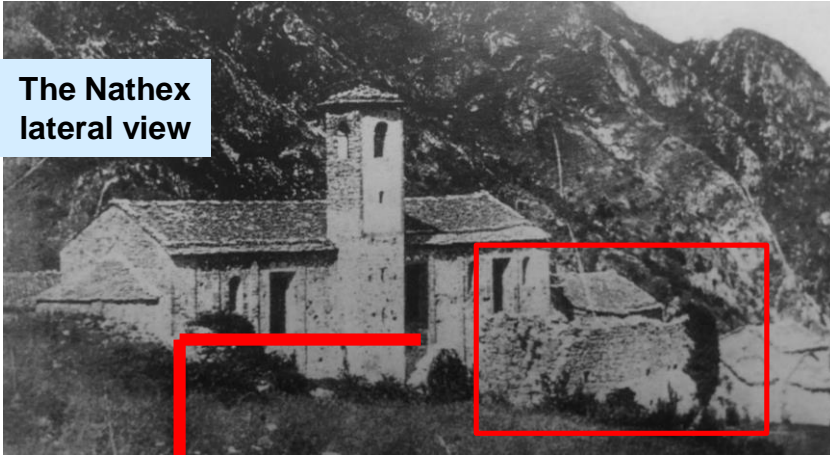

The Narthex Frontal view



Task 2 The Narthex (endonartece) and its Holy staircases



The Monastic complex of San Pietro al Monte Civate, Italy (VIII – XI Century)



Conservation-Restoration PROJECT

Design Problem

„Lime wash, weathering and the missing roof. What future for the **Covering of the Narthex?**“

The Narthex covering



TODAY

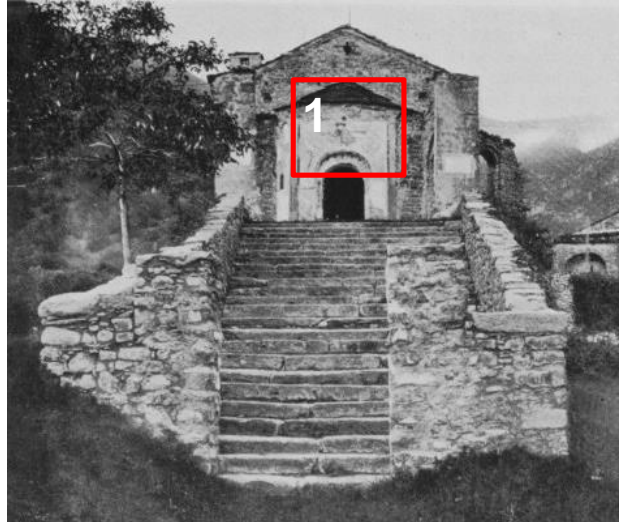

Conservation Problem



Task 3 Architectural Surfaces Interiors

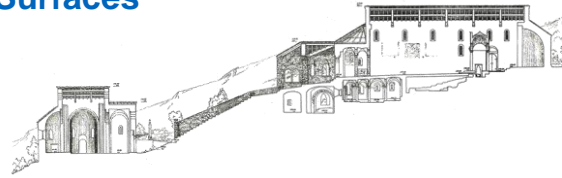

The Monastic complex of San Pietro al Monte
Civate, Italy (VIII – XI Century)



Conservation-Restoration PROJECT

„Fresco and Stucco Works“

Conservation Problem

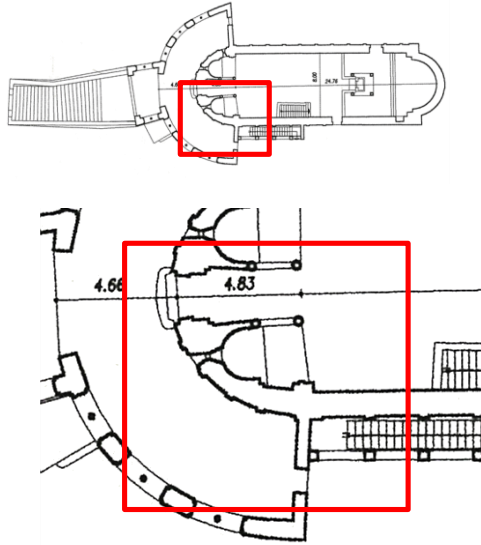

Task 3 Architectural Surfaces Interiors

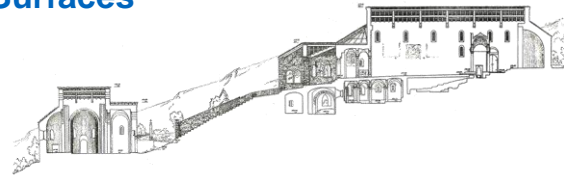

The Monastic complex of San Pietro al Monte
Civate, Italy (VIII – XI Century)



Conservation Problem

Conservation-Restoration PROJECT

„Fresco, Stucco and Stone Works“

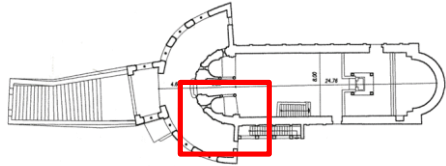

Terracotta

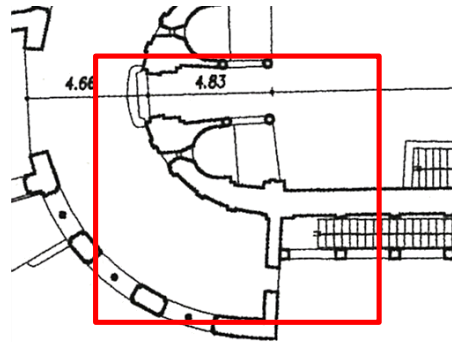

Stucco

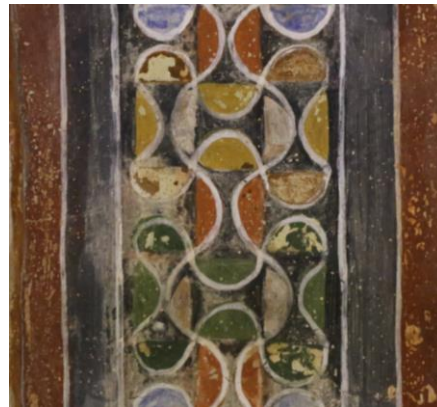

Stone



Brick



Tuff

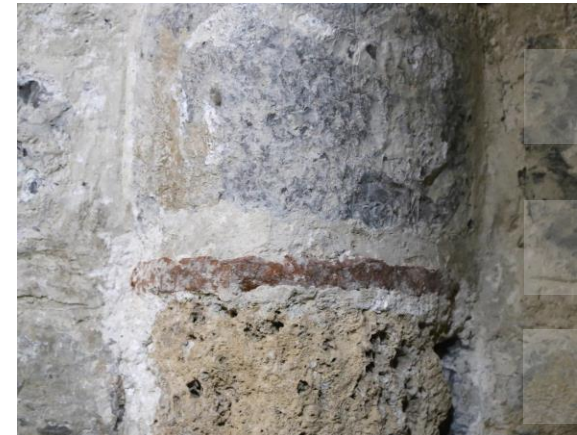

Task 3 Architectural Surfaces Interiors

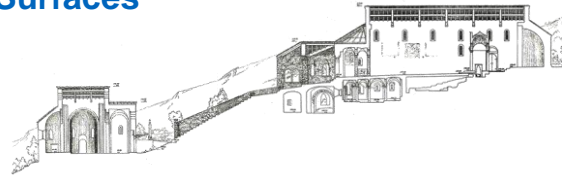

The Monastic complex of San Pietro al Monte
Civate, Italy (VIII – XI Century)



Conservation-Restoration PROJECT

„Terracotta, Stucco and Granite“

The Crypt

Conservation Problem

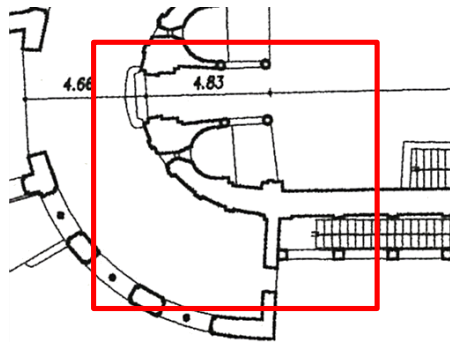
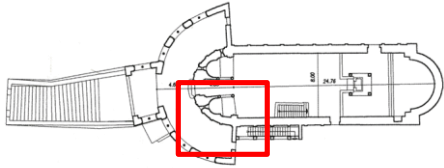

Task 4 San Benedetto (the small chapel)



The Monastic complex of San Pietro al Monte Civate, Italy (VIII – XI Century)



Conservation-Restoration PROJECT

Design Problem

„Which is the historic image we wish to transfer to posterity?“

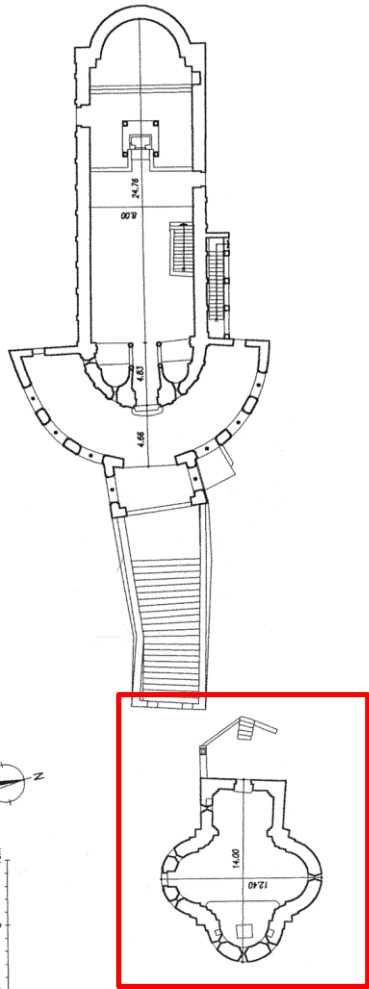

1 The new and old roof



2 The original vaulted ceiling

Task 5

Accessibility to the site and the Natura Park



The Monastic complex of San Pietro al Monte Civate, Italy (VIII – XI Century)



Conservation-Restoration PROJECT

Design Problem

„Shall we **preserve the original idea** of San Pietro al Monte as an **Hermitage**? Other shall we seek for means to activate **sustainable tourism**?“

Feigel, A. (1909). San Pietro in Civate.
Monatshefte Für Kunstwissenschaft, 2(4), 206-217.

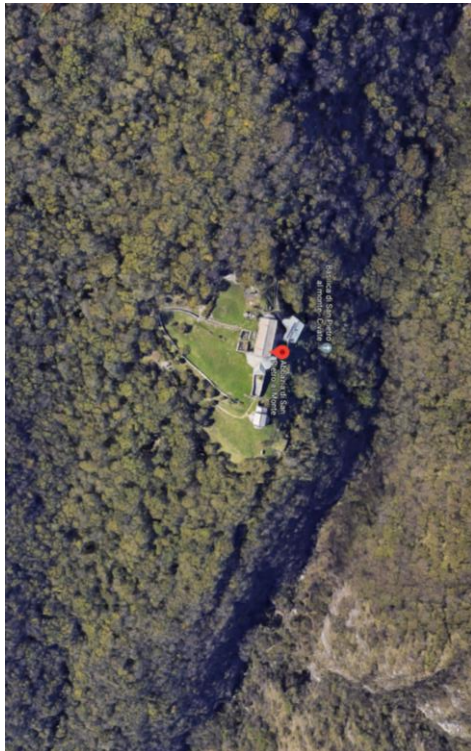

ACCESSIBILITY

"San Pietro in Civate will certainly **be unknown to most art lovers** and even to some of the more knowledgeable. Although writers from the XVIII. Century already pointed out **the beauty of the works of art hidden in this simple building and their importance** for the understanding of other famous monuments, it is only in more recent times that local researchers have taken a vivid interest in them. However, in the art-historical community little notice has been taken of these literature reference and of the works of art themselves. **This undeserved neglect is probably mainly due to specific local characteristics of the site** where the church is located: **Civate is far from the main roads leading to Italy, and the little church, which lies lonely, high up in the mountains, is difficult to reach.**"

Time Schedule

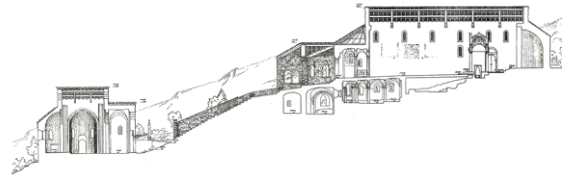

The Monastic complex of San Pietro al Monte
Civate, Italy (VIII – XI Century)



Kick off
Meeting

1st step

2nd step

3rd step

(1st step) Manufacturing
processes and techniques

Pin up 1

(2nd step) Materials,
Degradation patterns and
Restoration techniques

Pin up 2

(3rd step) Conservation-
Restoration Project

Final
Exam

Review Meetings:

April 13

June 01

July 07

Aug. 10

Best Works will be donated to the Parish church of Civate, to the Foundation: **Scuola Beato Angelico** of Milan and will be considered for publication on an issue of the **International Journal Arte Cristiana**